



Fast Ethernet Media Converter

Fast Ethernet Media Converter

ET-9003STM

ET-9003SCM

ET-9003SCS-15

ET-9003SCS-30

ET-9003SCS-60

ET-9003MTS-15

User's Manual

ΣDIMAX

FCC COMPLIANCE STATEMENT

This equipment generates and uses radio frequency energy and if not installed and used properly, that is, in strict accordance with the instructions provided with the equipment, may cause interference to radio and TV reception. The equipment has been tested and found to comply with the limits for a Class A computing device in accordance with the specifications in Subpart B of Part 15 of FCC rules, which are designed to provide reasonable protection against such interference in a commercial environment. However, there is no guarantee that interference will not occur in a particular installation.

If you suspect this equipment is causing interference, turn your converter on and off while your radio or TV is showing interference to determine the source of the interference.

You can try to correct the interference by one or more of the following measures:

1. Reorient the receiving radio or TV antenna where this may be done safely.
2. To the extent possible, relocate the radio, TV or the other receiver away from the equipment.
3. Plug the computer which has the equipment installed into a different power outlet so that equipment and the receiver are on different branch circuits.

If necessary, you should consult the place of purchase or an experienced radio/television technician for additional suggestion.

CAUTION : The phone jack cannot be connected to telephone system.

Contents

1. Introduction	1
2. Features & Specifications	2
3. Package Contents	4
4. Physical Description	6
5. Installation	9
6. Trouble-shooting	12

1.Introduction

Congratulations on your purchase of this product. This is a Fast Ethernet standard compliant media converter. This media converter allows users to convert the Fast Ethernet transmission media from UTP to fiber or fiber to UTP.

This media converter comes with two 100BaseTX twisted pair ports and a 100BaseFX fiber optic port. The UTP ports have two RJ-45 connectors and a maximum distance of 100 meters. The fiber optic port has an ST, SC or MT-RJ connector and a maximum distance of 2Km (Multi-Mode Fiber) to 60km (Single-Mode Fiber).

Fast Ethernet media converter's operation mode (Half-/Full-Duplex) is solely depending on the Fast Ethernet devices connected to. Users do not have to configure it.

2.Features & Specifications

(1) Features

- Complies with IEEE 802.3u 100BaseTX and 100BaseFX.
- Provides 100Mbps UTP and fiber media link.
- Fiber connectivity of up to 2 Km (Multi-mode) or 60 Km (Single-mode).
- Transparent translation between different media segments.
- Convenient uplink to switches/hubs through UTP uplink port.
- Auto-Negotiation, half/full- duplex.
- Complete sets of diagnostic LEDs.
- Plug and play installation.
- Compact and slim design.

(2) Specifications

- Standards: IEEE 802.3u 100BaseTX and 100BaseFX
- 100Mbps UTP Ports: RJ-45 x 2 (Normal x 1, Uplink x 1)
- 100Mbps Fiber Port:
 - ST x 1 (ET-9003STM)
 - SC x 1 (ET-9003SCM, ET-9003SCS-15,
ET-9003SCS-30, ET-9003SCS-60)
 - MT-RJ x 1 (ET-9003MTS-15)
- Fiber Media: Multi-mode Fiber (ET-9003xxM series) or Single-mode Fiber (ET-9003xxS-xx series)

- Distance:
 - 2Km (ET-9003SCM, ET-9003SCM)
 - 15Km (ET-9003SCS-15, ET-9003MTS-15)
 - 30Km (ET-9003SCS-30)
 - 60Km (ET-9003SCS-60)
- Transmission Mode: Full-Duplex or Half-Duplex (according to connected device)
- LEDs: Power, Full-Duplex, Fiber Link/Activity, UTP Link/Activity
- Dimensions:
 - 24 (H) x 123(W) x 83(D) mm (ET-9003STM)
 - 24 (H) x 123(W) x 84(D) mm (ET-9003SCM, ET9003SCS-15/30/60)
 - 24 (H) x 123(W) x 86(D) mm (ET-9003MTS-15)
- Power : 12VDC, 0.5A
- Operating Temperature: 32-131°F (0-55°C)
- Operating Humidity: 10-95% (Noncondensing)
- Certification: FCC Class A, CE Mark, C-Tick

3.Package Contents

- One Fast Ethernet Converter
- One Power Adapter
- User's Manual

ET-9003STM
Multi-mode

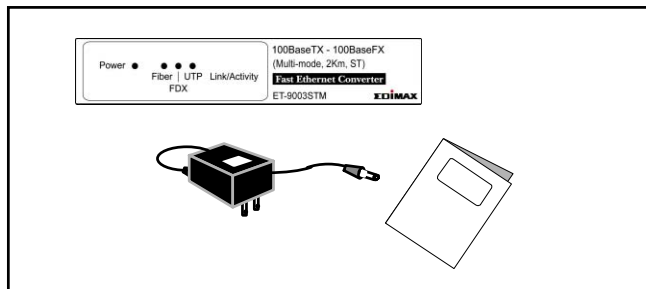

ET-9003SCM
Multi-mode

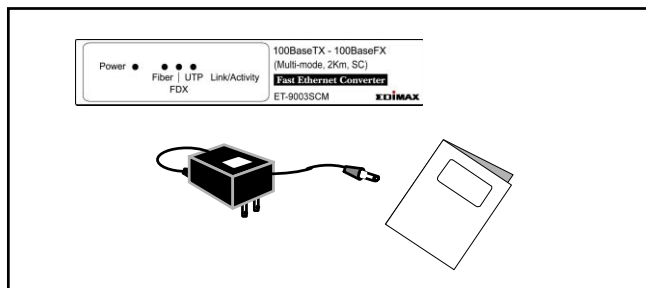

ET-9003SCS-15
Single-mode

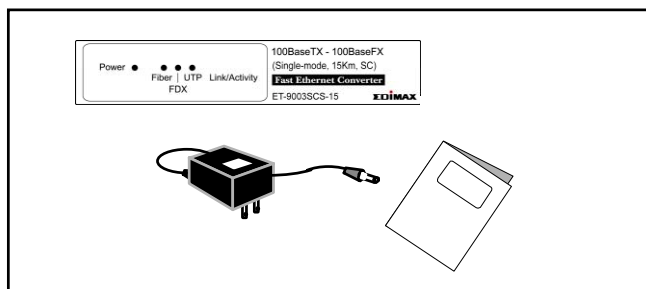

ET-9003SCS-30
Single-mode

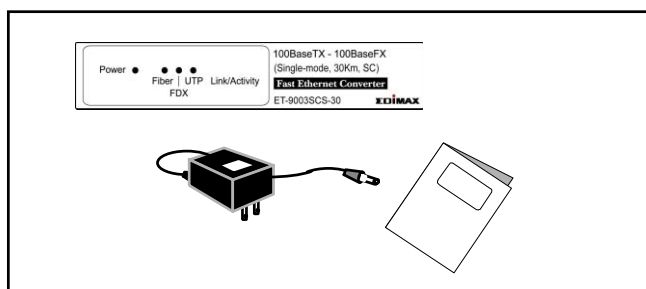

ET-9003SCS-60
Single-mode

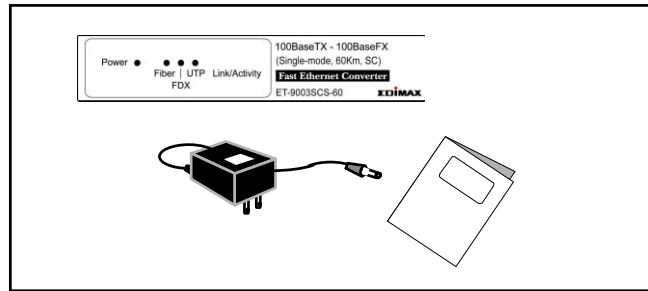

ET-9003MTS-15
Single-mode

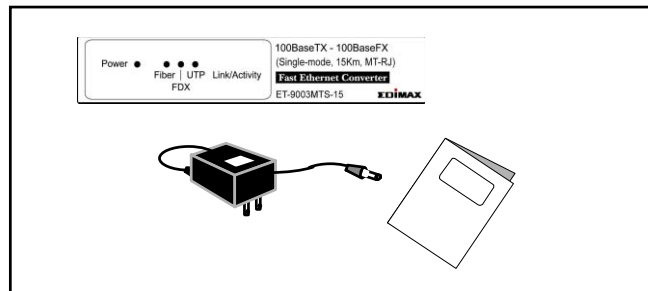

4. Physical Description

(1) Panel

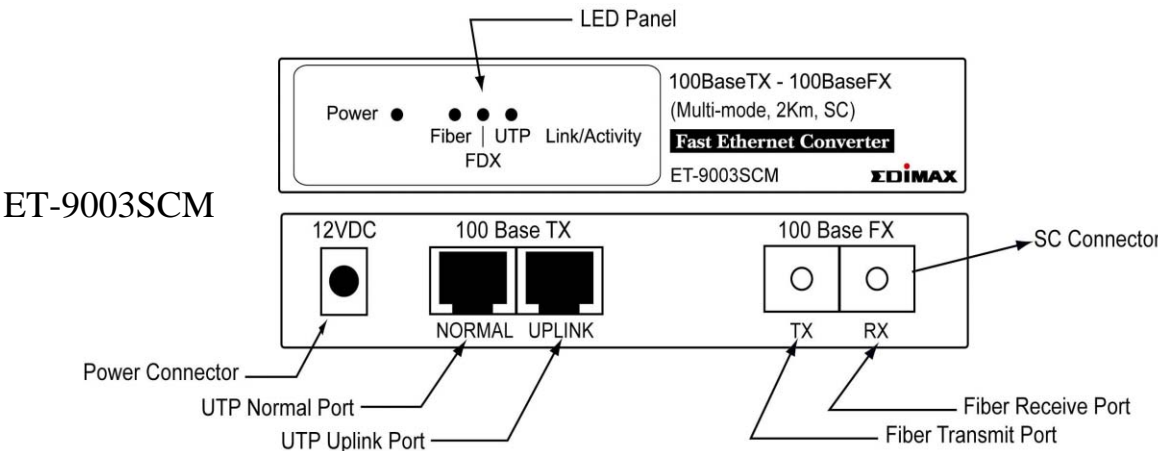
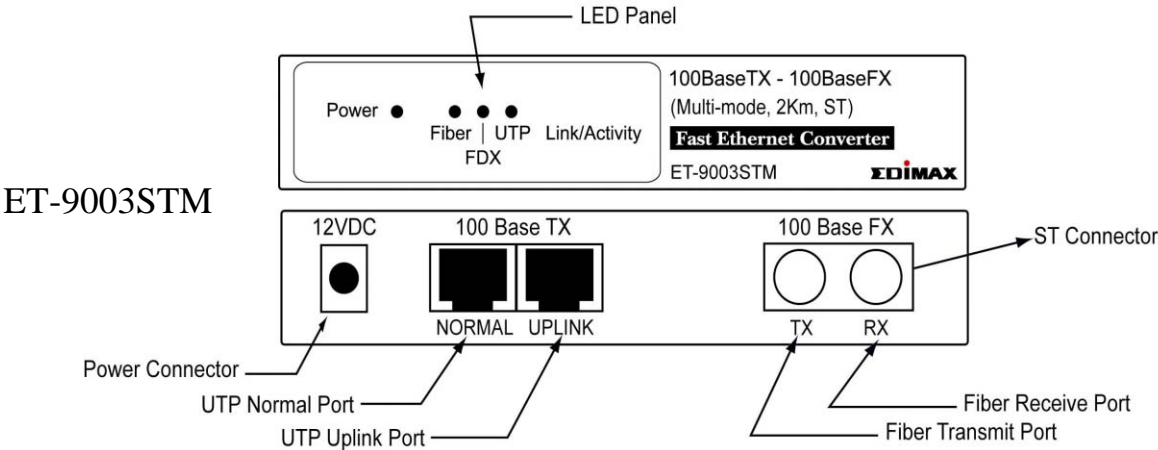

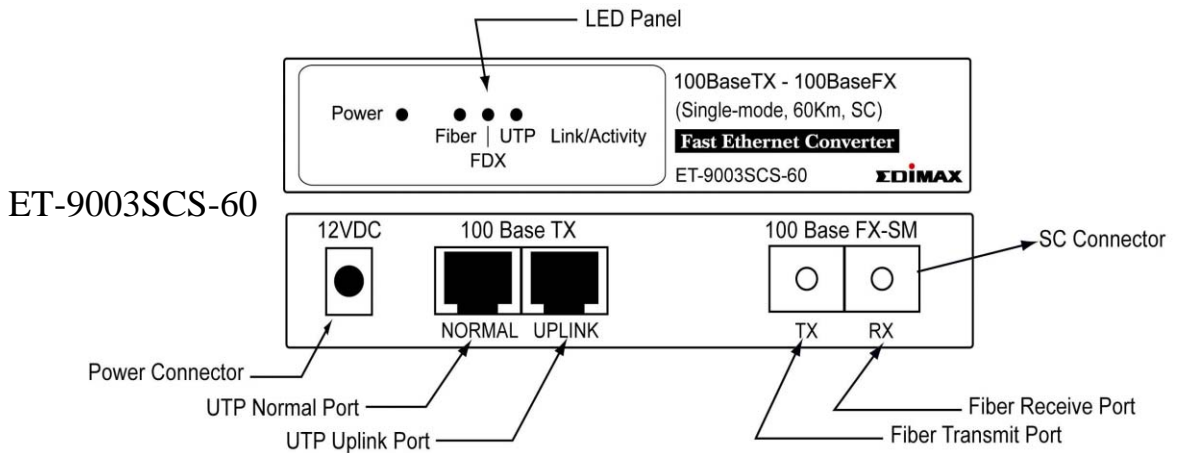
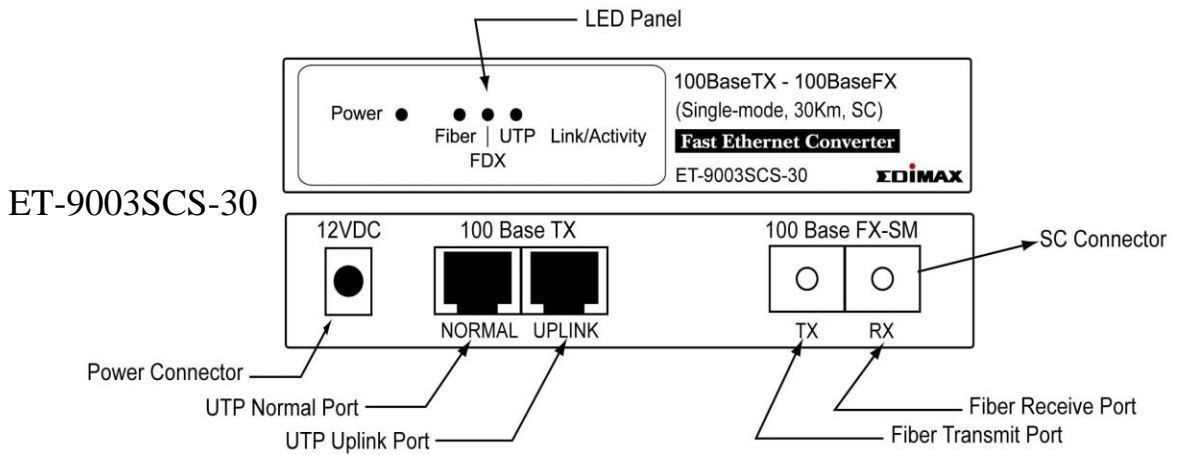
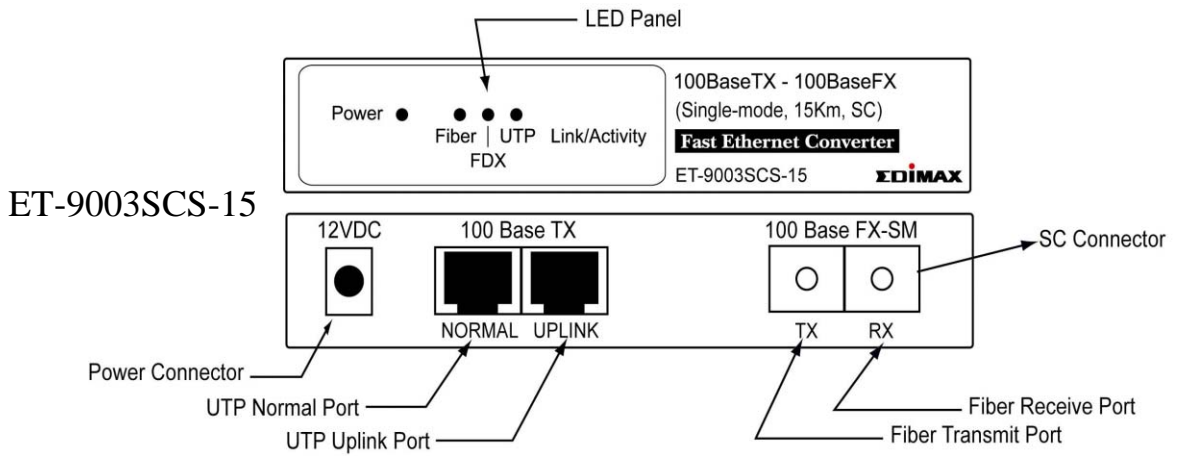

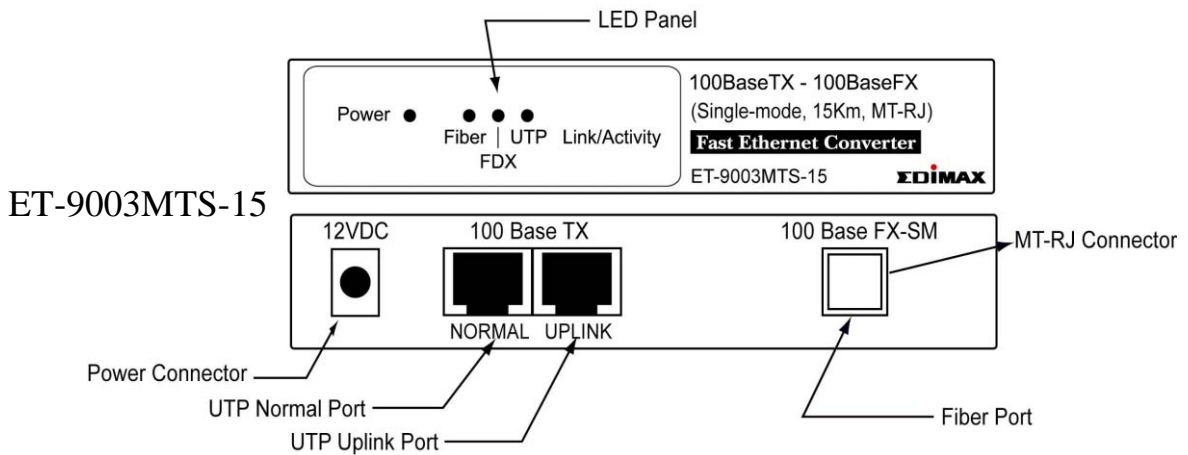

(2) LED

LED	Color	Status	Description	Number of LED
Power	Green	Lit	Power is supplied	One for the converter
		Off	No Power	
FDX	Green	Lit	This converter runs at Full-Duplex	One for the converter
		Off	This converter runs at Half-Duplex	
Fiber Link/Activity	Green	Lit	A valid link is established	One for the fiber port
		Flash	Data packets are received	
		Off	No link is established	
UTP Link/Activity	Green	Lit	A valid link is established	One for the UTP port
		Flash	Data packets are received	
		Off	No link is established	

5. Installation

(1) Operating Environment

This converter must be installed and operated within the limits of specified operating temperature and humidity (see previous section under Specifications). Do not place objects on top of the unit. Do not position the converter near any heating source such as heater, radiator, or direct exposure to sun. Prevent entering of water and moisture into the unit. If necessary, use dehumidifier to reduce humidity.

(2) Guidelines for installation

Please observe following guidelines when you are installing the media converter.

- The nodes connected to the media converter must operate at 100Mbps.
- The two nodes connected to the ports of the media converter must operate with the same duplex mode.
- The devices connected to the media converter can be network adapter, hubs, switches or routers.
- The network configuration with media converter could be any one of the following architectures.

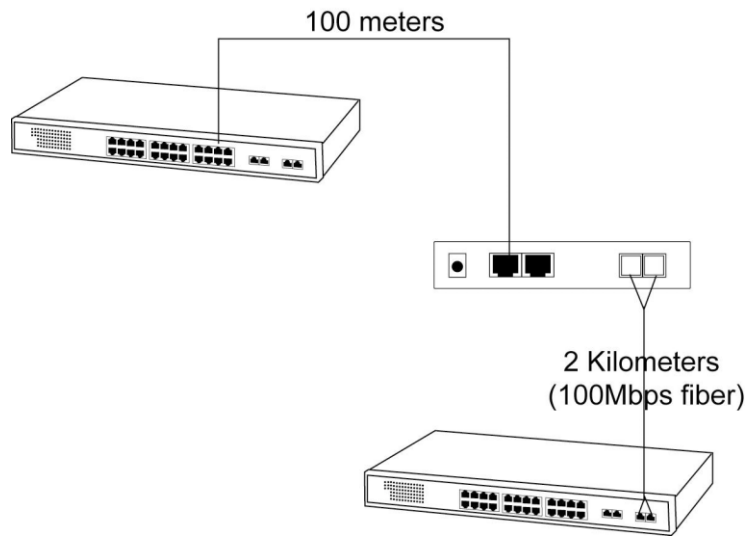

Standalone Configuration

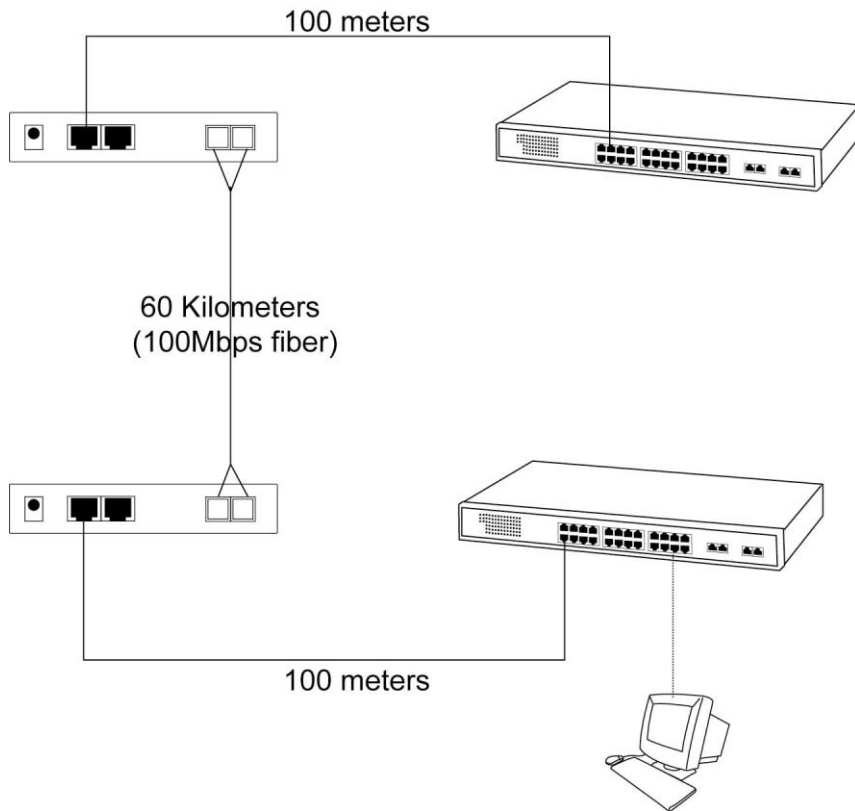

Back-to-Back Configuration

(3) Connecting the cable

Make sure the UTP and fiber cables are properly connected to the converter. Using the normal category 5 UTP straight-through cable for connecting the UTP normal port to PC/adaptor or connecting the UTP uplink port to hub port. Using 50/125 or 62.5/125 micron multi-mode fiber to connect to the fiber port of multi-mode media converter. Using 9/125 micron single-mode fiber to connect to the single-mode media converter.

(4) Connecting the power

Connect the output end of the power adapter to the power connector on the rear panel of the converter. Connect the power adapter to the power outlet. The green Power LED on the front panel of the hub should be lit.

6. Trouble-shooting

1. UTP or Fiber Link LED is not lit

- Check the power switch on the network device connected to the converter, make sure it is turned ON.
- Check the network cable; make sure the UTP cable complies with EIA/TIA 568 specification and fiber optic cables comply with industry standards.

2. Fail to transmit data

- Make sure the UTP distance does not exceed 100m.
- If the FDX LED does not light (not operates in full-duplex mode), make sure the fiber distance does not exceed the maximum distance listed below. If the FDX LED lights, the fiber distance should not exceed the available maximum distance of the converter, for example 2km or 60Km.

100BaseFX Fiber Optic Port Connection Distance at Half-Duplex

Number of Media Converters	Connected Devices	Maximum Distance
One Media Converter	Switch to Switch	372 m
	Workstation to Switch	372 m
	Switch to Class I Repeater	137 m
	Switch to Class II Repeater	185 m
Two Media Converters	Switch to Switch	332 m
	Workstation to Switch	332 m
	Switch to Class I Repeater	97 m
	Switch to Class II Repeater	145 m

[!] Contact your dealer if problem persist.