



# Gigabit Switch

## **Gigabit Smart Switch**

**8 Ports 1000/100/10Mbps**

**ES-5800D+**

**ES-5800R+**

**User's Manual**

**ΣDIMAX**

## FCC COMPLIANCE STATEMENT

This equipment has been tested and found to comply with the limits of a Class A computing devices, pursuant to Part 15 of the FCC rules. These limits are designed to provide reasonable protection against harmful interference. This equipment generates, uses and can radiate radio frequency energy and, if not installed and used in accordance with the instructions, may cause harmful interference to radio communications.

If you suspect this product is causing interference, turn your computer on and off while your radio or TV is showing interference. If the interference disappears then when you turn the computer off and reappears then you turn the computer on, something in the computer is causing interference.

You can try to correct the interference by one or more of the following measures:

1. Reorient/relocate the receiving antenna.
2. Increase the separation between the equipment and receiver.
3. Connect the equipment into an outlet on a circuit difference from that to which the receiver is connected.
4. Ensure that all expansion slots (on the back or side of the computer) are covered. Also ensure that all metal retaining brackets are tightly attached to the computer.

---

# Content

---

|   |           |
|---|-----------|
| <b>1. Introduction .....</b>                  | <b>3</b>  |
| <b>2. Features &amp; Specifications .....</b> | <b>4</b>  |
| <b>3. Package Contents.....</b>               | <b>6</b>  |
| <b>4. Hardware Description.....</b>           | <b>7</b>  |
| <b>5. Advance Smart Function Setting ...</b>  | <b>9</b>  |
| <b>5.1 Login Page .....</b>                   | <b>11</b> |
| <b>5.2 Top Screen.....</b>                    | <b>12</b> |
| <b>5.3 Port Status.....</b>                   | <b>13</b> |
| <b>5.4 Port Configuration.....</b>            | <b>14</b> |
| <b>5.5 Mirror Port Configuration....</b>      | <b>15</b> |
| <b>5.6 VLAN Configuration .....</b>           | <b>16</b> |
| <b>5.7 Trunk Configuration.....</b>           | <b>17</b> |
| <b>5.8 MISC Configuration .....</b>           | <b>18</b> |
| <b>5.9 Set Password.....</b>                  | <b>19</b> |
| <b>6. Troubleshooting .....</b>               | <b>21</b> |

---

# 1. Introduction

---

Congratulations on your purchase of this eight ports Gigabit Smart Switch. This high performance Gigabit switch provides eight 1000/100/10Mbps Gigabit Ports to allow simultaneous transmission of multiple packets via an internal high-speed data channel.

The built in console interface can be used to configure the switch's settings for **priority queuing, VLAN, Trunking, Port Monitoring and Port speed.**

This Gigabit switch utilizes store-and-forward switching architecture that filters and forwards data after the complete data packet is received and examined to be free of errors. The front panel of this switch provides LEDs for easy recognition of the switch operation status and for troubleshooting.

All the Gigabit ports support both **Full and Half duplex** which are able to provide up to 2000Mbps of bandwidth to the connected devices, with **auto-negotiation** providing the capability to connect to **1000/100/10Mbps** network devices. It also supports backpressure and **IEEE 802.3x advanced flow control** capabilities that can reduce congestion and prevent packet loss.

In addition, all the ports support the **MDI/MDI-X** auto-detect function. That is to say, you can connect any device (including PC, Switch, Hub) to a port of this switch using a regular cable. The RJ-45 port will auto-detect and auto-switch to the correct MDI/MDI-X mode (do not need to use a specific uplink port or cross-over cable).

---

## 2. Features & Specifications

---

### Features

- Complies with the IEEE802.3 Ethernet, IEEE802.3u Fast Ethernet and IEEE 802.3ab Gigabit Ethernet Standards (gigabit over copper)
- Provides Store-and-Forward architecture and full wire speed filtering and forwarding rate
- Provides eight 10/100/1000Mbps Gigabit switching ports (RJ-45 connector)
- All ports provide Auto-Negotiation and Auto-MDI/MDI-X functions
- Supports flow control: Back pressure for Half-duplex and IEEE 802.3x for Full-duplex mode
- Supports Port-based VLAN(up to 8 groups)
- Supports QoS(IEEE 802.1p) : 4 Priority queues per port
- Supports Port Mirroring
- Supports Console configuration
- Desktop : 11” compact size designed  
Rackmount : 19” rackmount size designed

## Specifications

- **Standards:** IEEE802.3 10BaseT, IEEE802.3u 100BaseTX and IEEE802.3ab 1000BaseT copper over Ethernet
- **Total Ports:** 8 10/100/1000Mbps auto-sensing Fast Ethernet/Gigabit Ethernet ports
- **Media Interface:** RJ-45
- **Forwarding Method:** Store-and-Forward
- **MAC Address:** 8K
- **Buffer Memory:** 256KBytes
- **Flow control:** Back pressure for half-duplex and IEEE802.3x for full-duplex
- **Advance configuration functions:**
  - VLAN setting: Port-based VLAN up to 8 groups
  - Trunking: Up to 2 trunking groups
  - Priority Queuing (CoS) setting
  - Port Mirroring
- **Auto-negotiation:** All ports
- **Auto MDI/MDIX function:** All ports
- **System LED indication:** Power
- **Port LED indication:**
  - FULL/COL: Full duplex / Collision
  - Speed: 10/100/1000Mbps
  - LNK/ACT: Link / Activity
- **Operation Temperature:** 50~131 (10~55 )
- **Operation Humidity:** 10~95% (Non-condensing)
- **Power:** 100~240V AC, full range internal power supply
- **Emission:** FCC Class A, CE, C-Tick

---

## 3. Package Contents

---

### Packing list

Check the contents of your package for following parts:

- One Gigabit Switch
- One User's manual
- One Power cord
- One RS-232 Cable

**If any of the items are missing or damaged, please contact your local dealer.**

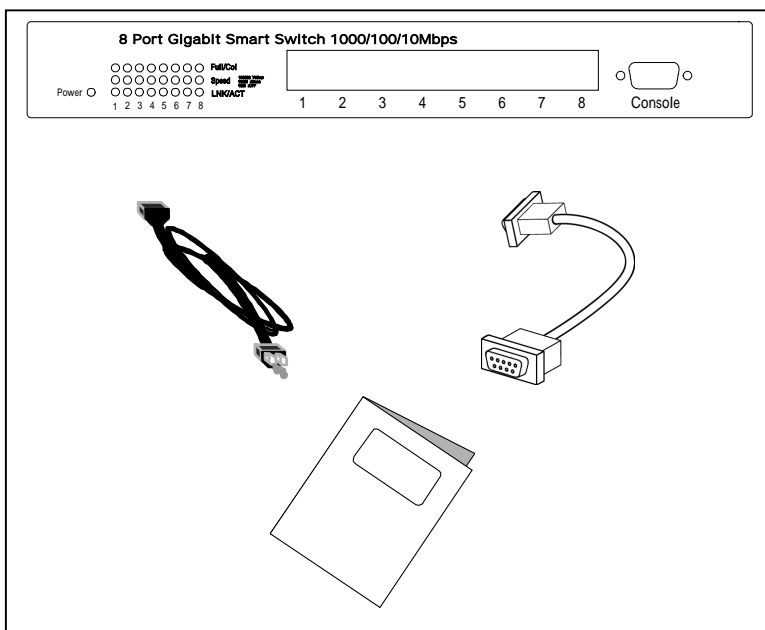

## 4. Hardware Description

This section describes the hardware features of this Gigabit Smart Switch. For easier management and control of the switch, familiarize yourself with its display indicators and ports. All LEDs are located on the front panel of the switch. They serve the purpose of monitoring the operation and performance of the switch at a glance.

- LED indicators

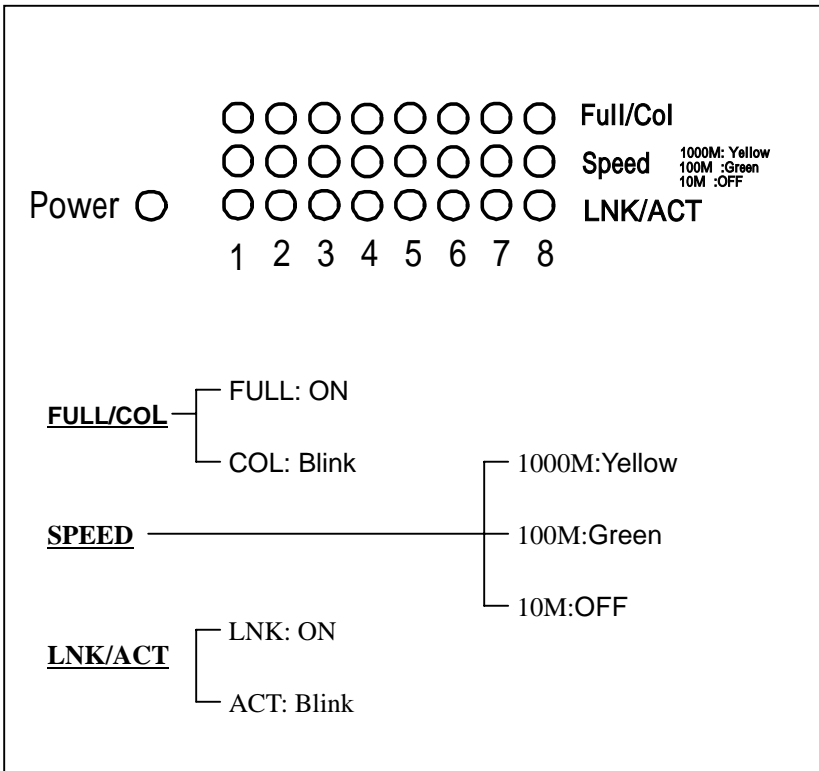

## **Operating Environment**

This switch must be installed and operated within the limits of the specified operating temperature and humidity (see previous section on Specifications). Do not place objects on top of the unit or obstruct any vents at the sides of the unit. Do not position the unit near any heating source such as heaters, radiators, or direct exposure to sun. Do not expose the unit to water and or moisture. If necessary, use a dehumidifier to reduce humidity.

## **Connecting to network devices**

1. All ports of this switch support the Auto-MDI/MDI-X function. That is to say, you can connect any device (including PC, Switch, Hub) to a port of this switch using a regular cable. The RJ-45 port will auto-detect and auto-switch to the correct MDI/MDI-X mode. (do not need to connect to a specific uplink port or cross-over cable)
2. Connect one end of the network cable to the RJ-45 port on the front panel, and connect the other end of the network cable to the RJ-45 port on the network device. Follow the same procedure to connect all the RJ-45 ports of the switch. Maximum length, using UTP cable, between the switch and connected device is 100 meters (300ft). Once the network cable is connected to both ends and the attached network device is powered on, the LNK/ACT LED should be lit.
3. Make sure the wiring is correct. You need to use Category 3/4/5 cable for 10Mbps operation or Category 5 cable for 100Mbps and Gigabit (1000Mbps) connections.

## **Connecting the power**

Plug the power cable into the internal three pronged power plug, and connect it to an electrical outlet.

---

## 5. Advance Smart-Function Setting

---

This switch provides advance features, which offers you more flexibility in setting up your network. The following section explains how to set up the **VLAN, Trunking, Speed, Port Mirror, Full/Half duplex and QoS modes**.

### Before using advance Configuration

#### *Connect to PC*

**Attach a RS-232 serial cable 9-pin male connector to the female connector on the switch. Plug the other side of this cable to your PC.**

#### *Using Hyper Terminal to connect to Switch*

**In MS-Windows, launch “Hyper Terminal”, create a new connection, and follow these steps:**

1. Open the HyperTerminal application
2. In Windows, select run from the start menu and choose the application.
3. From the HyperTerminal menu, double click the icon and create a new name on the next window, such as Gigabit Smart Switch.

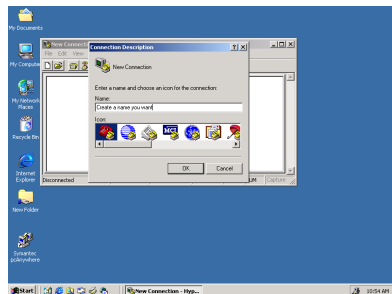
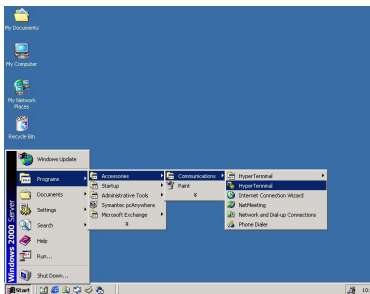

#### 4. Adjust the setting of the communication port.

4.1 Select the using by connect interface such as COM1,COM2

4.2 Select the Bits per second at “9600”

4.3 Set the flow control value as “None”.

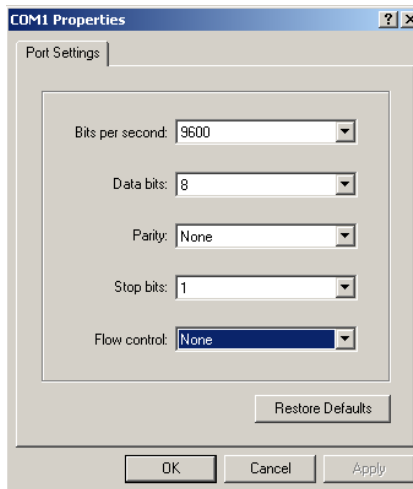

---

## 5.1 Login Page

---

Once you have powered on the switch, it will boot up and enter the initial system screen as shown. If this is your first time to log into the configuration program, then the default user name is “admin” with password “admin”. After you have entered the correct user name and password, you will have access to the system configuration program.

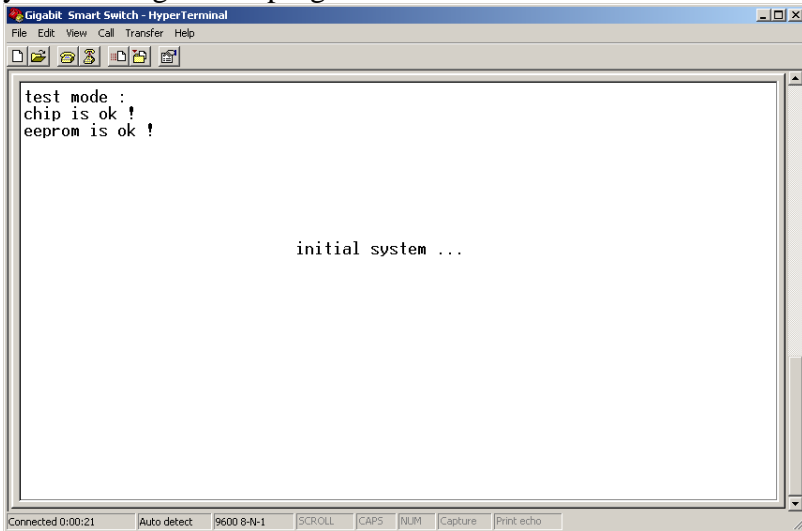

```
Gigabit Smart Switch - HyperTerminal
File Edit View Call Transfer Help
test mode :
chip is ok !
eeprom is ok !

initial system ...

Connected 0:00:21 Auto detect 9600 8-N-1 SCROLL CAPS NUM Capture Print echo
```

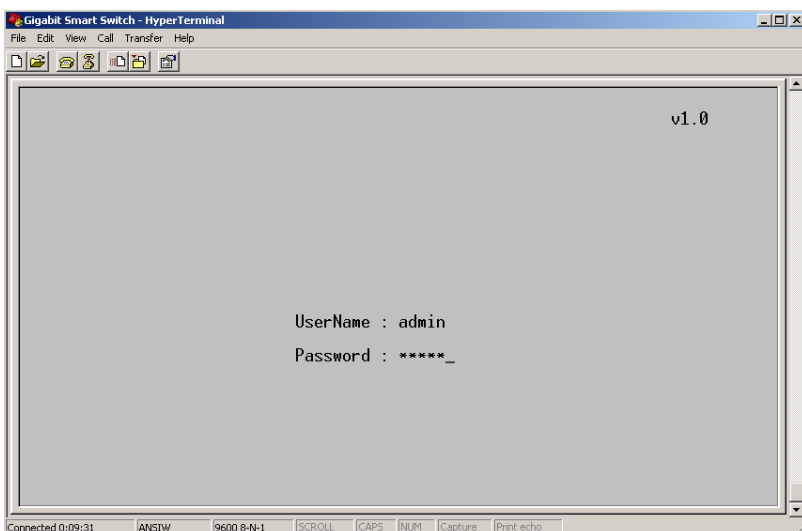

```
Gigabit Smart Switch - HyperTerminal
File Edit View Call Transfer Help
v1.0

UserName : admin
Password : *****_

Connected 0:09:31 ANSIR 9600 8-N-1 SCROLL CAPS NUM Capture Print echo
```

## 5.2 Top Screen

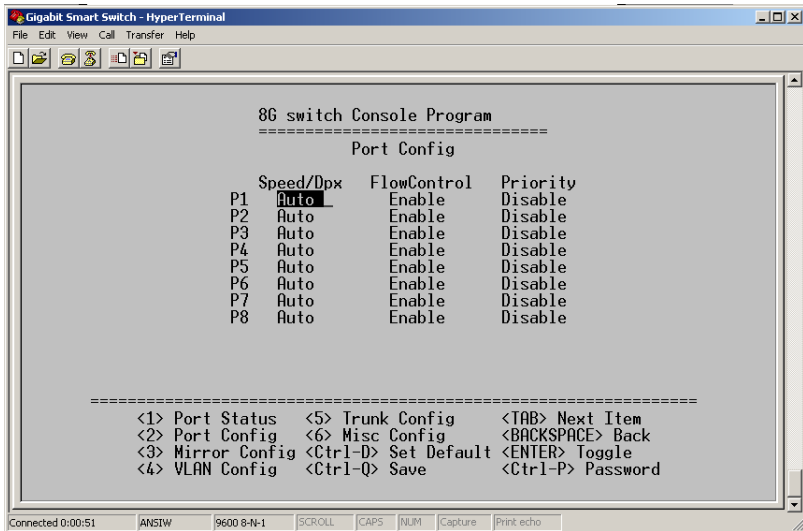

Once you log on to the Smart Switch's system configuration program with a console terminal emulator software (e.g. Hyper Terminal), the default Port Configuration screen seen above will appear. With the system configuration program you can define system parameters, manage and control the switch and all its ports, or monitor network conditions.

**Note:** Use the number key to select the function screen you want to set. Press <Tab> to move between the items and then press <Enter> to change the value.

- 1.Port Status:** Indicates the port's speed and link status.
- 2.Port Configuration:** Sets up the speed and enables/disables the flow control and priority function.
- 3.Mirror Port Configuration:** Monitors traffic at the ports.
- 4.VLAN Configuration:** Sets up the VLAN group of the switch.
- 5. Trunk Configuration:** Sets up the trunking groups.
- 6.MISC Configuration:** Sets up the aging time.

## 5.3 Port Status

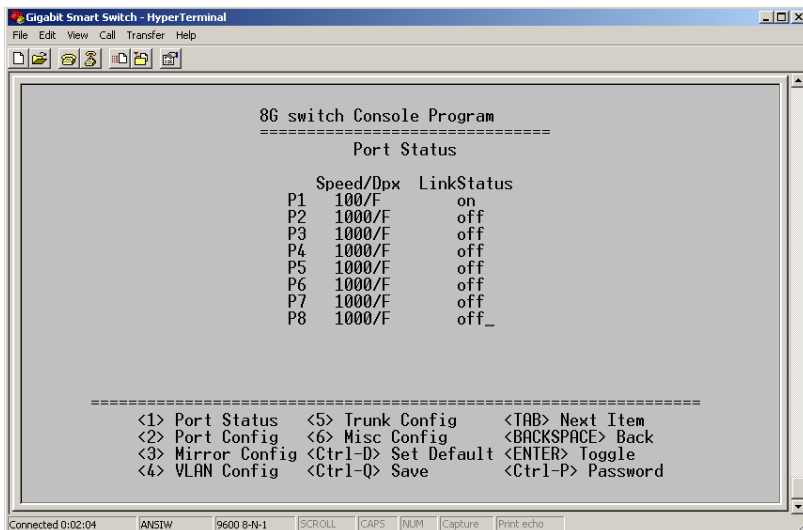

The screenshot shows a terminal window titled "Gigabit Smart Switch - HyperTerminal". The main display area contains the following text:

```
86 switch Console Program
=====
Port Status

Speed/Dpx  LinkStatus
P1  100/F    on
P2  1000/F   off
P3  1000/F   off
P4  1000/F   off
P5  1000/F   off
P6  1000/F   off
P7  1000/F   off
P8  1000/F   off_

=====
<1> Port Status  <5> Trunk Config  <TAB> Next Item
<2> Port Config <6> Misc Config  <BACKSPACE> Back
<3> Mirror Config <Ctrl-D> Set Default <ENTER> Toggle
<4> VLAN Config <Ctrl-Q> Save      <Ctrl-P> Password
```

At the bottom of the terminal window, there is a status bar with the following information: "Connected 0:02:04", "ANSIW", "9600 8-N-1", "SCROLL", "CAPS", "NUM", "Capture", and "Print echo".

Press <1> to display the port status.

The Speed/Dpx parameter represents the speed (10, 100 or 1000Mbps) and half/full duplex mode of the port. For example, 100/F represents the network is 100Mbps with full duplex mode. If the network is connected, the LinkStatus shows ON, otherwise it shows OFF.

## 5.4 Port Configuration

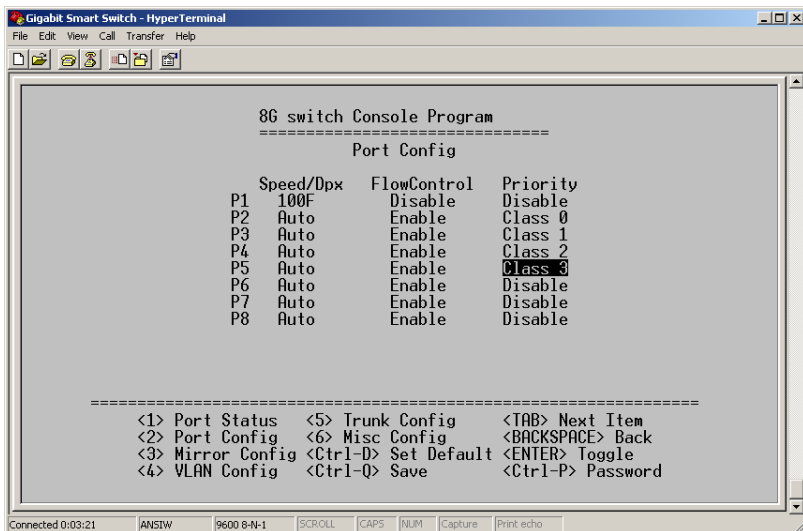

```
8G switch Console Program
=====
Port Config

Speed/Dpx  FlowControl  Priority
P1  100F      Disable      Disable
P2  Auto       Enable       Class 0
P3  Auto       Enable       Class 1
P4  Auto       Enable       Class 2
P5  Auto       Enable       Class 3
P6  Auto       Enable       Disable
P7  Auto       Enable       Disable
P8  Auto       Enable       Disable

=====
<1> Port Status  <5> Trunk Config  <TAB> Next Item
<2> Port Config  <6> Misc Config  <BACKSPACE> Back
<3> Mirror Config <Ctrl-D> Set Default <ENTER> Toggle
<4> VLAN Config  <Ctrl-Q> Save      <Ctrl-P> Password
```

Press <2> to set up the Port configuration. In this screen, you can set up the port speed, enable or disable the flow control function and set up the priority queues.

1. In the Speed/Dpx column, it has six kinds of speed modes. By pressing <Enter>, you can choose AUTO, 1000F, 100F, 100H, 10F or 10H (F and H represent Full duplex and Half duplex respectively.) to set the speed mode of the port.
2. In the second column (FlowControl), you can press <Enter> to enable or disable the flow control function.
3. At the last column, you can set up the Priority queues of each port. It provides four classes of service: class 0(low), class 1(normal), class 2(high) and class 3(very high).

---

## 5.5 Mirror Port Configuration

---

```
86 switch Console Program
-----
Mirror Config

Port Mirroring: Enable
Monitored Port: 3
Snooping Port : 1
Monitored Pkts: Incoming&Outgoing

-----
<1> Port Status   <5> Trunk Config   <TAB> Next Item
<2> Port Config  <6> Misc Config   <BACKSPACE> Back
<3> Mirror Config <Ctrl-D> Set Default <ENTER> Toggle
<4> VLAN Config  <Ctrl-Q> Save     <Ctrl-P> Password
```

The switch supports port monitoring. This feature provides a complete network monitoring capability for each port. A copy of egress (Tx) data and ingress (Rx) data of the monitored port is sent to their respective snooping ports.

The monitored port configuration function allows us to monitor the port traffic. We can press <Enter> to enable or disable the function. If you enable the port mirroring function, you should set up the monitored port (for example, we set port 3 as monitored port as shown above) and snooping port (port 1 for example). There are three kinds of packets you can choose to monitor: Incoming, Outgoing and Incoming&Outgoing. Press <Enter> to select the kind of packets you want to monitor.

---

## 5.6 VLAN Configuration

---

```
86 switch Console Program
=====
VLAN Config

VLAN0: [Enable ] 12345678 [vvv----]
VLAN1: [Enable ] [---vv--]
VLAN2: [Disable]
VLAN3: [Disable]
VLAN4: [Disable]
VLAN5: [Disable]
VLAN6: [Disable]
VLAN7: [Disable]

=====
<1> Port Status   <5> Trunk Config   <TAB> Next Item
<2> Port Config  <6> Misc Config   <BACKSPACE> Back
<3> Mirror Config <Ctrl-D> Set Default <ENTER> Toggle
<4> VLAN Config  <Ctrl-Q> Save     <Ctrl-P> Password

Connected 0:05:24  ANSIW  9600 8-N-1  SCROLL  CAPS  NUM  Capture  Print echo
```

Port-based VLAN is the simplest form of VLAN. This switch allows you to create multiple VLANs, each with its own broadcast domain and member ports.

In this screen, you can choose the members of the VLAN group and then press enter to configure as in the following steps:

1. Choose the VLAN group you want to set up and press Enter to enable it.
2. Press <Tab> to move to the next column and choose the port you want to include. For example, we set up port 1,2 and port 3 in the same VLAN group as shown.

**Note:** This unit can offer up to 8 VLAN groups, and allows overlapping of several separate VLANs.

## 5.7 Trunk Configuration

```
8G switch Console Program
=====
Trunk Config
Trunk A(P1-P2) : Enable
Trunk B(P7-P8) : Disable
Balancing Method: Source&Dest addr based

=====
<1> Port Status   <5> Trunk Config   <TAB> Next Item
<2> Port Config  <6> Misc Config   <BACKSPACE> Back
<3> Mirror Config <Ctrl-D> Set Default <ENTER> Toggle
<4> VLAN Config  <Ctrl-Q> Save     <Ctrl-P> Password
```

This switch can setup two channel aggregation links, named “Trunk A” and “Trunk B”, of 2 ports each. Trunk channel A is comprised from ports 1 and 2, while trunk channel B is comprised from ports 7 and 8. You can press <ENTER> to enable or disable this function.

There are three parameters of Balancing Method:

**source port based method**

**source address based method**

**source and destination addresses based method**

---

## 5.8 MISC Configuration

---

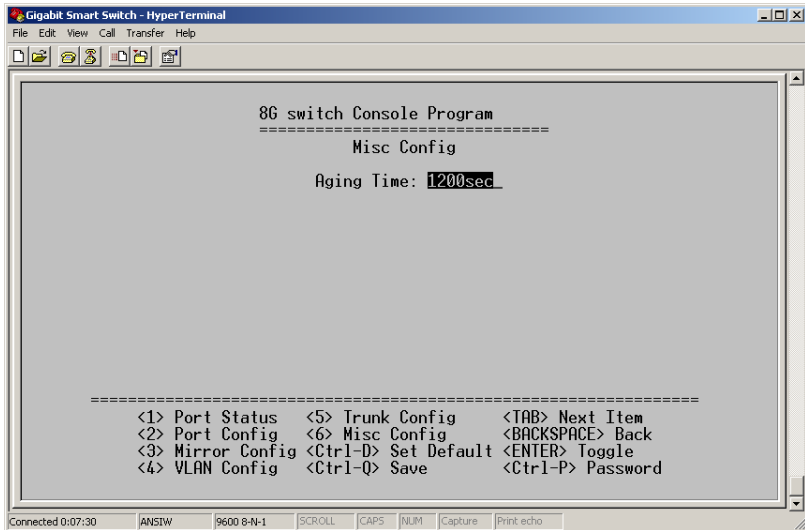

In this screen, you can set up the aging time. You can select 300, 600, 900, 1200 seconds or just disable it.

---

## 5.9 Set Password

---

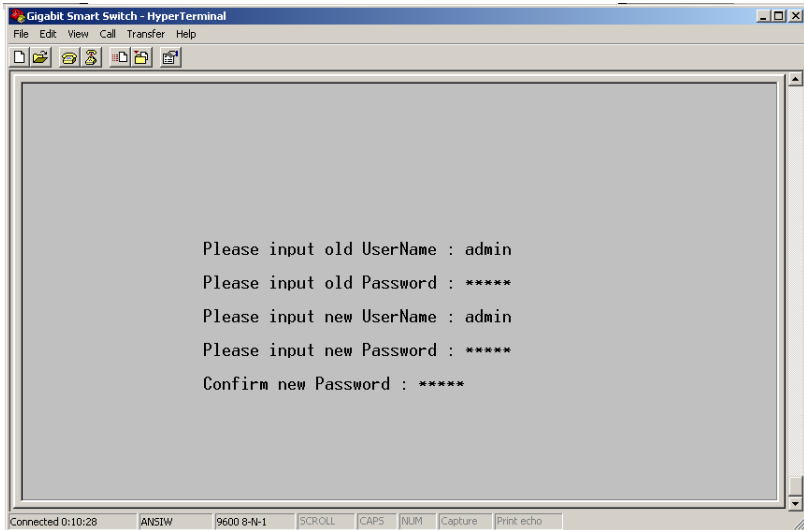

Press <Ctrl-P>, you can change the username and password. In this function, you should fill in the old username and password, then enter the new username, new password and confirm it.

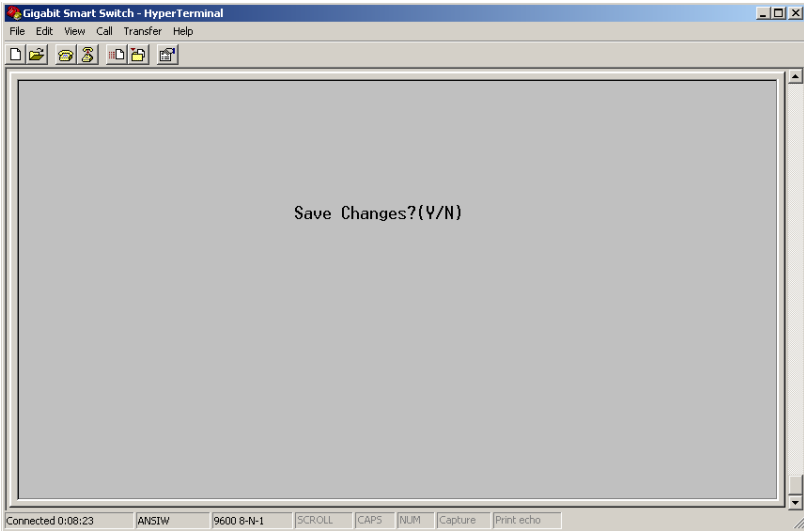

After all the configurations were set up, remember to store it with <Ctrl-Q>. The switch will save the configuration and exit the system.

You can restore all the configurations setting to the original values by pressing <Ctrl-D>.

---

## **6. Troubleshooting**

---

### **1. Power LED is not lit**

Check if the power cord is properly connected to the power outlet and the switch.

### **2. Link LED is not lit when connected to the network device**

- (1) Check if the network cable is properly connected to the switch and the network device
- (2) Make sure the UTP cables comply with EIA/TIA 568 and Category 5 specification

### **3. Collision LED flashes constantly**

- (1) Remove all the network cables; connect the cables back one by one to isolate the source of the collision.
- (2) Check the network cable, inferior cable quality will result in excessive collisions and packet errors.

**[!] Contact your dealer if problems persist.**